

CATSKILL

C R A F T S M E N , I N C .

Assembly Instructions Model 1461 Stainless Steel Butcher Block Cart

A. These units are Ready-To-Assemble. Catskill uses positive fastening methods such as wood screws and nuts and bolts. You will need some common household tools like a screwdriver, crescent wrench or socket wrench set, hammer, as well as a clear flat area to assemble the cart.

B. Directions (left/right, front/back) are given as facing the front of an assembled upright unit.

C. A friend is recommended to assist with assembly as this will ease the process. Some of the parts are large and awkward to hold in place, and an extra pair of hands are a huge help.



Model 1461

Exploded view of cart for reference during assembly.

Please follow the assembly instructions carefully.

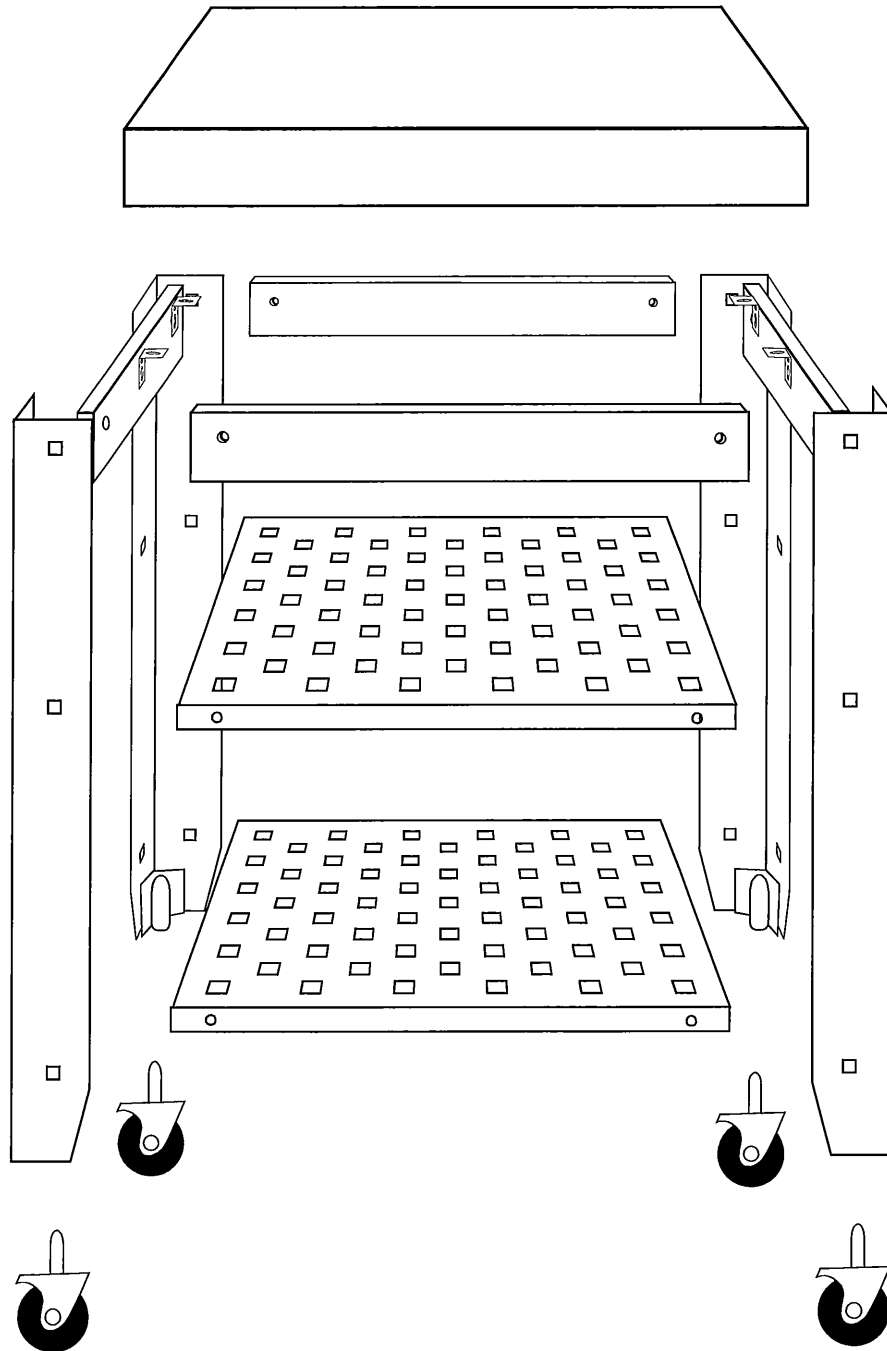

Model 1461

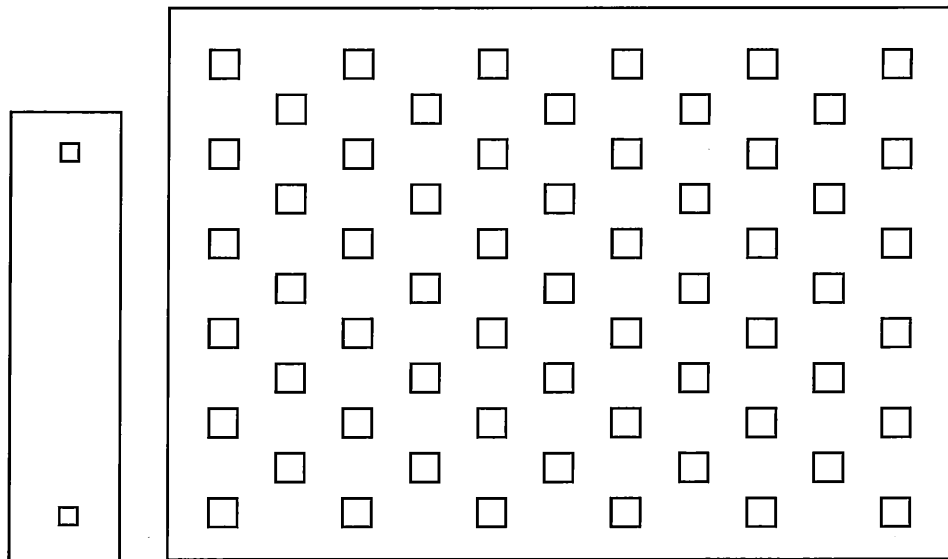

Part#: 1461MetalShelf (2)

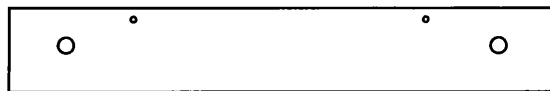

Part#: 1461WoodTableTopBrace-Short (2)

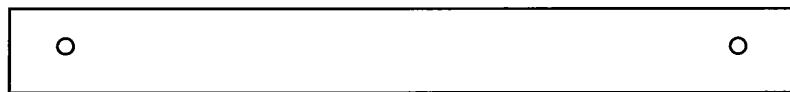

Part#: 1461WoodTableTopBrace-Long (2)



Part#: 1461MetalLeg (4)

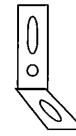

Part#: 1461" L" Bracket (4)



Part#: 1461Washer(24)



Part#: 1461Locking nuts (24)

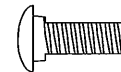

Part#: 1461Stainless 1" Bolt (8)



Part#: 1461Stainless 3/4" Bolt (16)

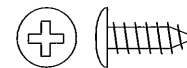

5/8" Pan Head #6 Screw (8)

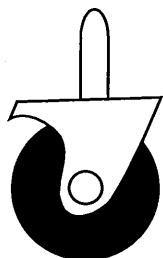

Part#: 1461Wheel (4)

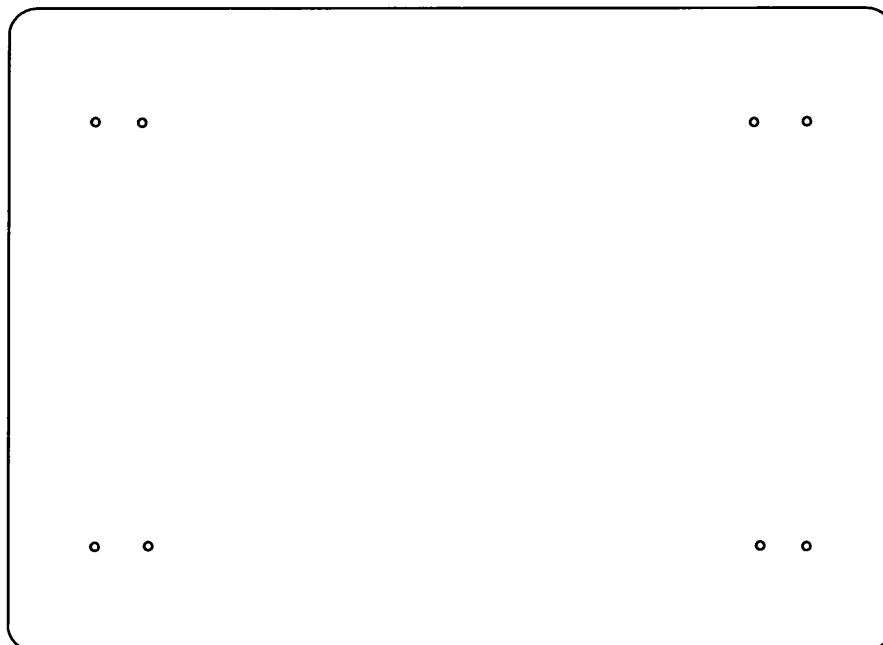

Part#: 1461ButcherBlockTableTop

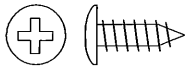

5/8" Pan Head #6 Screw
Four (4) used in this step.

1

Attach "L" brackets to the bottom of the table top using 5/8" #6 Pan Head Screws.

"L" Bracket should be positioned such that the hole rather than the slot is used (as shown in illustration.)

Use holes closest to table top edge

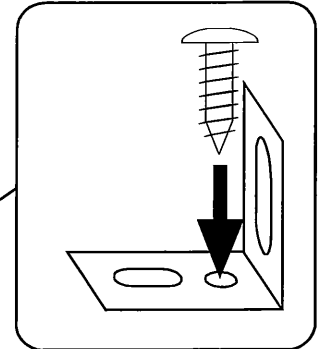
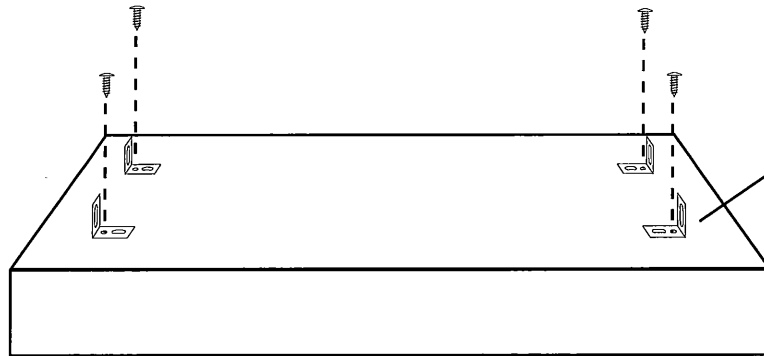

IMPORTANT! Peel off the protective plastic film from all stainless steel parts before beginning assembly.

2

Attach the top wooden side brace to two legs using the 1" stainless bolts securing with a washer and locking nut to each leg.

IMPORTANT: Make sure pilot holes for attaching the "L" brackets face towards the inside of the cart as shown in the illustration.

Repeat for other legs.



Washer
Four (4) used in this step.



Locking Nut
Four (4) used in this step.

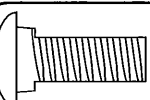

1" Stainless Steel Bolt
Four (4) used in this step.

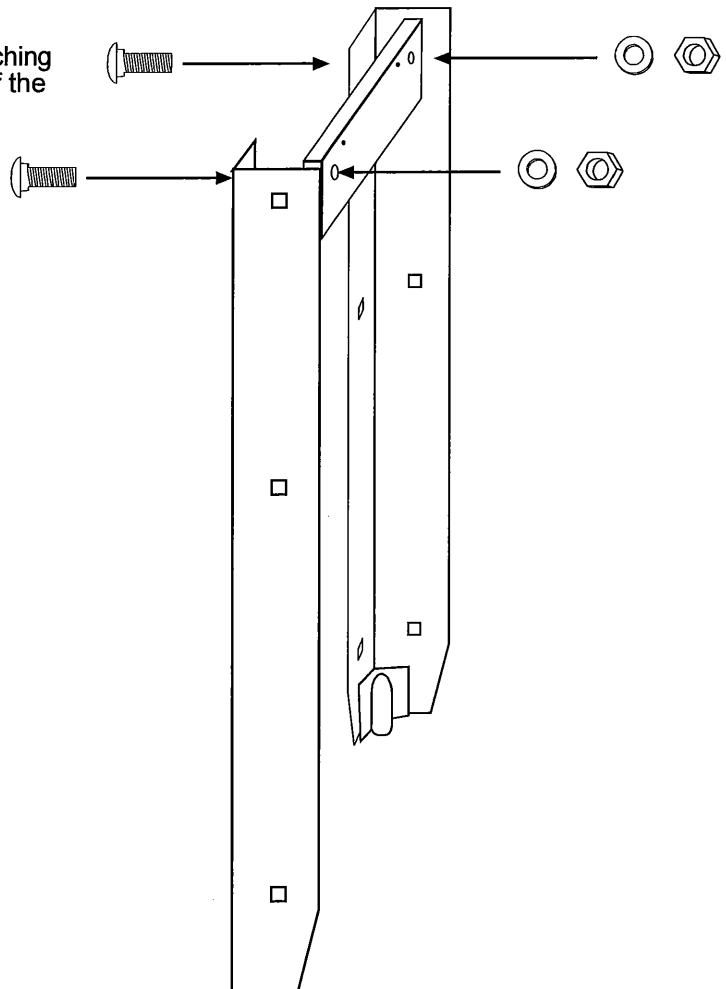

4

Attach the front and back wooden top braces using the 1" stainless steel bolts securing with the washers and locking nuts.



Washer
Four (4) used in this step.



Locking Nut
Four (4) used in this step.

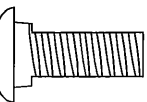

1" Stainless Steel Bolt
Four (4) used in this step.

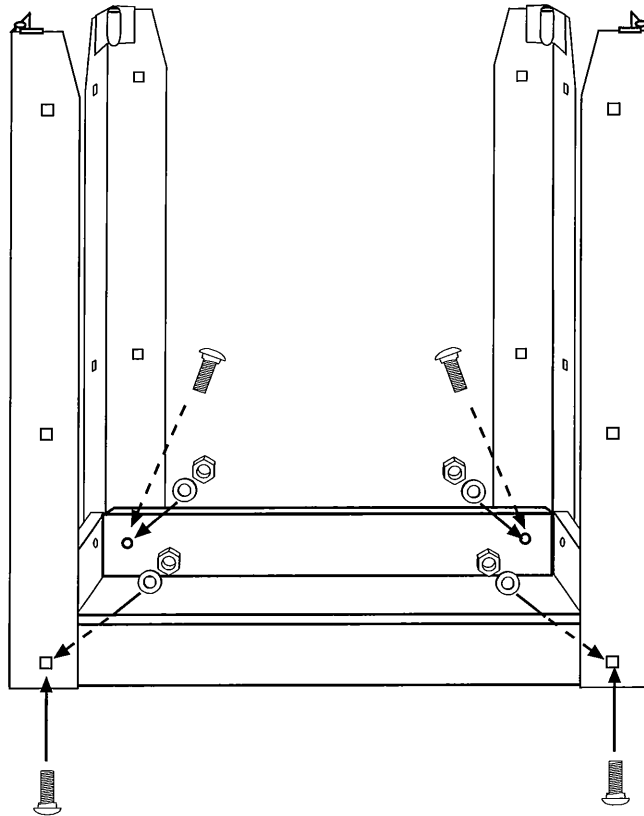

5

Attach the leg assemblies to the inverted table top using 5/8" #6 pan head screws, securing through the "L" brackets into the wooden side braces.

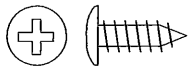

5/8" Pan Head #6 Screw
Four (4) used in this step.

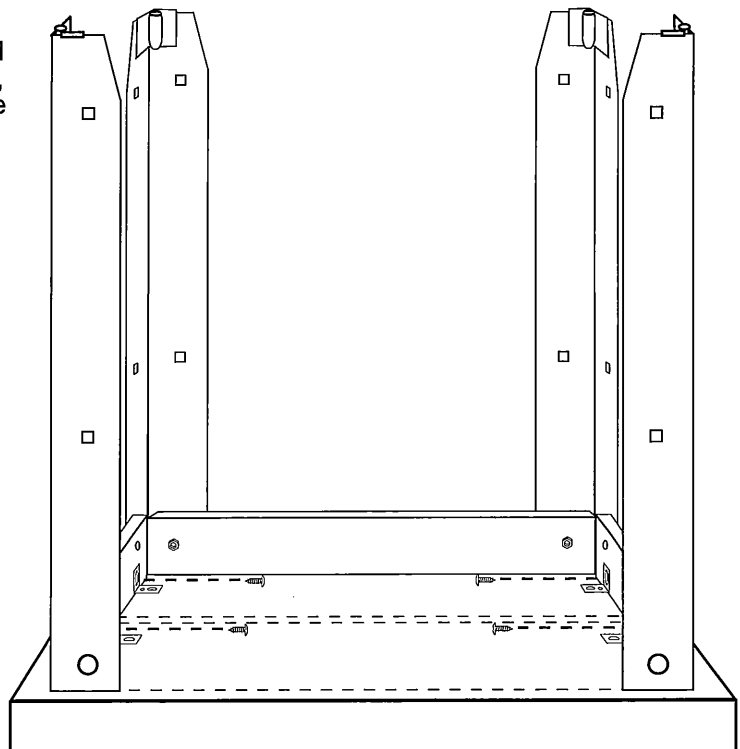

6

Attach shelves to leg assemblies using 3/4" stainless steel bolts, securing with washers and locking nuts.

Insert all bolts and begin all washers and nuts before tightening.

Once all the bolts are in place, then tighten down the locking nuts.



Washer
Four (16) used in this step.



Locking Nut
Four (16) used in this step.

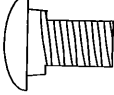

3/4" Stainless Steel Bolt
Four (16) used in this step.

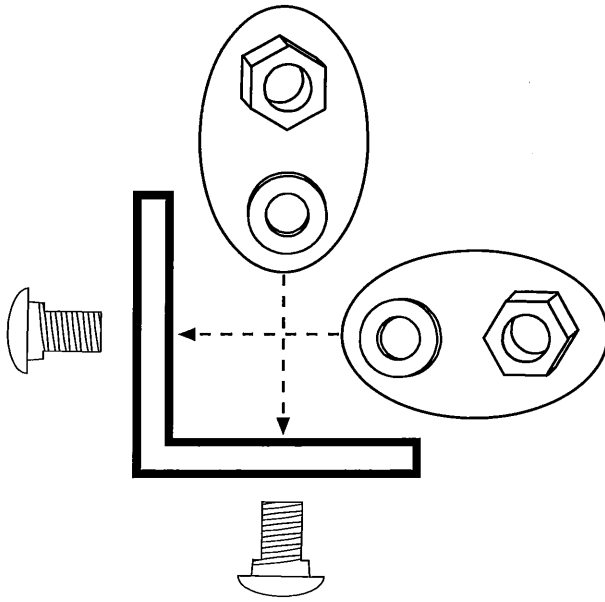
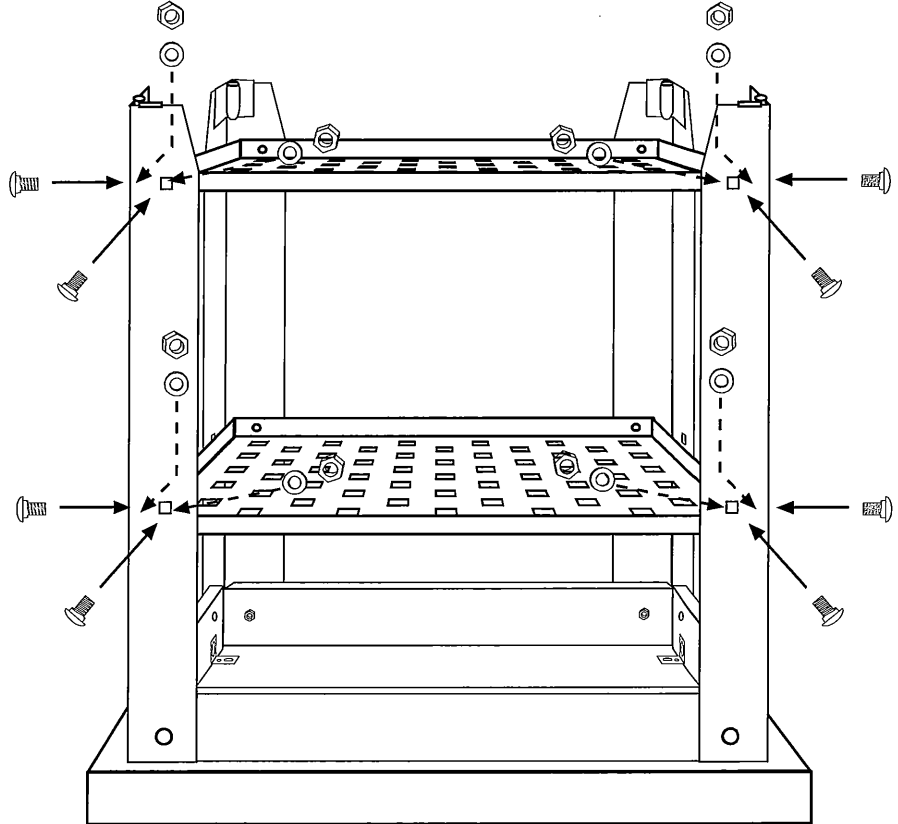

Each shelf attaches to each leg in two locations as shown in this birds eye view illustration of the leg.

7

Tap the wheel casters into place using a hammer.

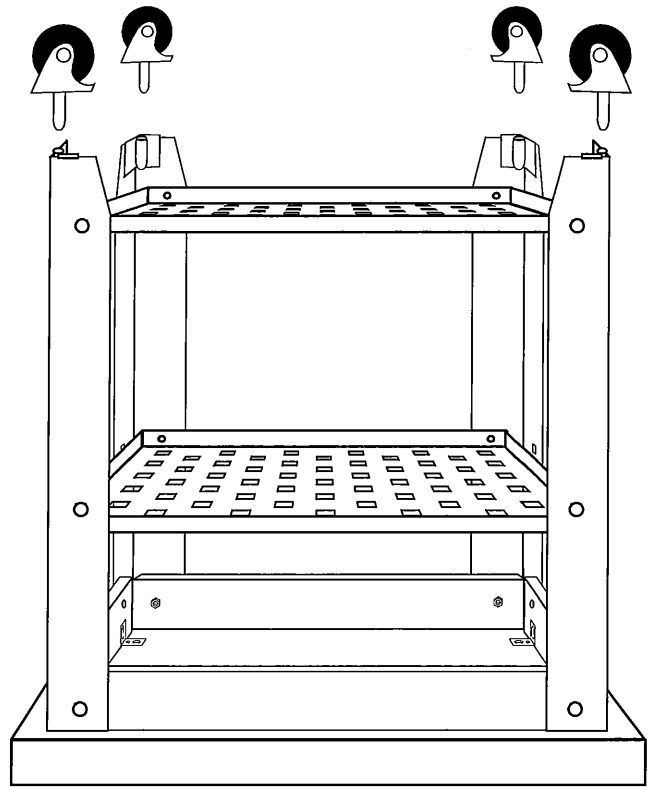

8

Set the cart upright. **IMPORTANT!** As the cart is heavy and awkward once assembled, it is strongly suggested to have two people set the cart upright.

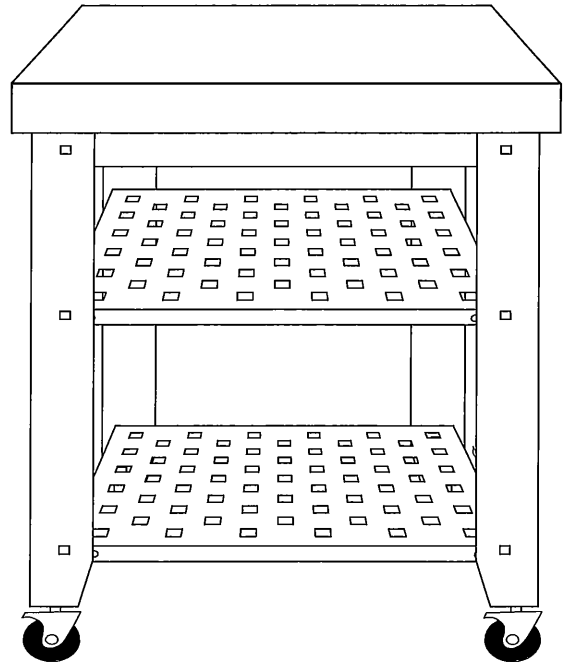



**REDUCED PRICE TO
OUR CUSTOMERS!**

For continued beauty and long life of your Catskill Craftsmen cart, we recommend Catskill Craftsmen's Butcher Block Oil.

Our Butcher Block Oil is available directly from Catskill Craftsmen's factory. For one eight ounce (8 fl. oz.) bottle, which is sufficient for two applications, simply send \$6.95 along with the completed coupon to the address below. If you prefer, you can visit us online at www.catskillcraftsmen.com and use your visa or mastercard.

CATSKILL
C R A F T S M E N , I N C .

Catskill Craftsmen, Inc.
15 West End Ave.
Stamford, NY 12167-1296

CATSKILL
C R A F T S M E N , I N C .

BUTCHER BLOCK OIL COUPON

Please send me _____ # of bottle(s) of the
Catskill Craftsmen Butcher Block Oil at \$6.95.
My check or money order is enclosed for a
total of \$ _____.

Item code: 1461

Name _____

Address _____

City _____

State _____ Zip _____

Please make checks payable to Catskill Craftsmen
Inc. 15 West End Ave., Stamford, NY 12167-1296